

German Technology, Since 1929.

www.focusun.com

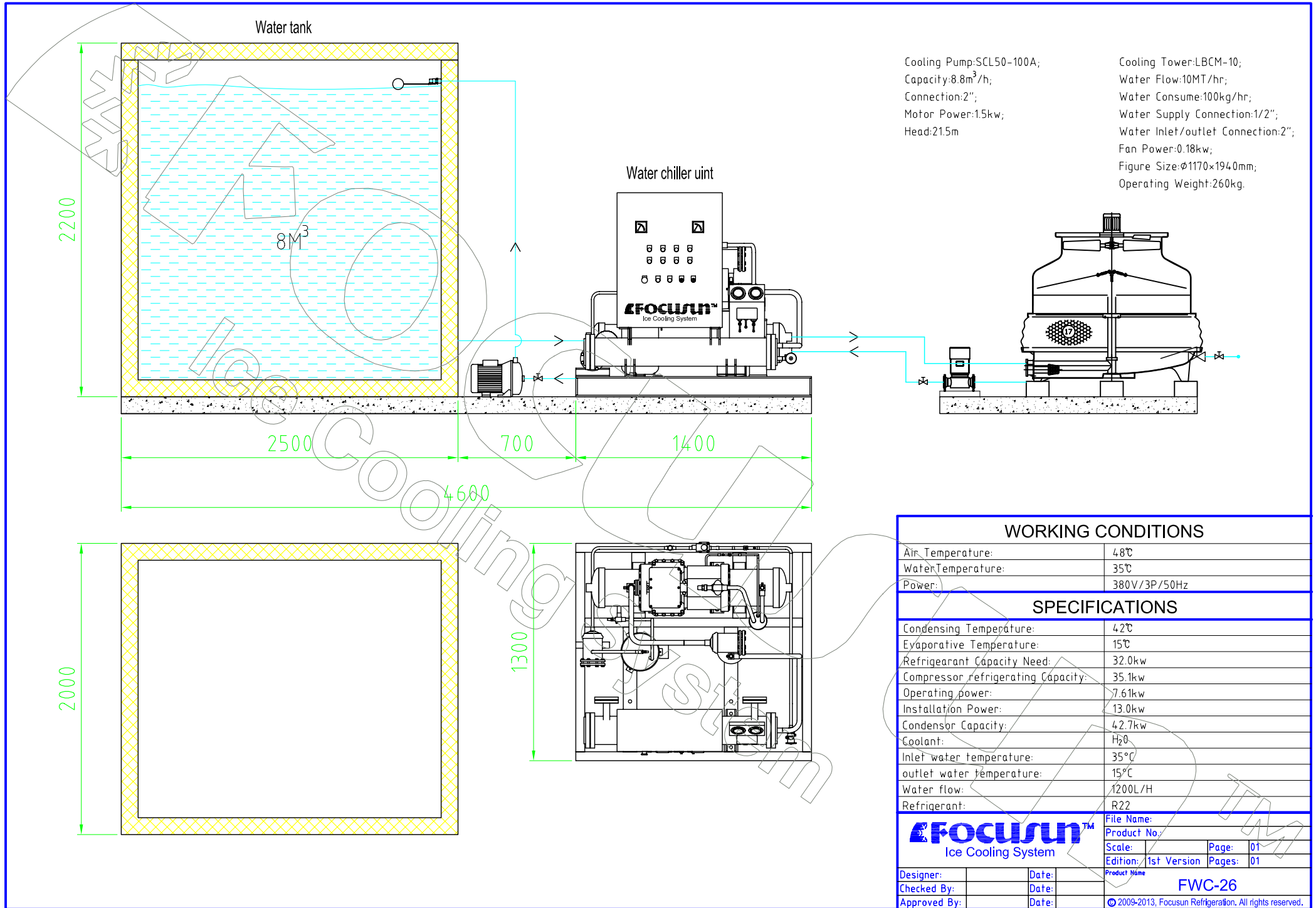

Cooling Pump:SCL50-100A;
Capacity:8.8m³/h;
Connection:2";
Motor Power:1.5kw;
Head:21.5m

Cooling Tower:LBCM-10;
Water Flow:10MT/hr;
Water Consume:100kg/hr;
Water Supply Connection:1/2";
Water Inlet/outlet Connection:2";
Fan Power:0.18kw;
Figure Size:φ1170×1940mm;
Operating Weight:260kg.

WORKING CONDITIONS

Air Temperature:	48°C
Water Temperature:	35°C
Power:	380V/3P/50Hz

SPECIFICATIONS

Condensing Temperature:	42°C
Evaporative Temperature:	15°C
Refrigerant Capacity Need:	32.0kw
Compressor refrigerating Capacity:	35.1kw
Operating power:	7.61kw
Installation Power:	13.0kw
Condensor Capacity:	42.7kw
Coolant:	H ₂ O
Inlet water temperature:	35°C
outlet water temperature:	15°C
Water flow:	1200L/H
Refrigerant:	R22

FOCUSUN™ Ice Cooling System		File Name:	
		Product No.:	
Designer:	Date:	Scale:	Page: 01
Checked By:	Date:	Edition: 1st Version	Pages: 01
Approved By:	Date:	Product Name: FWC-26	
© 2009-2013, Focusun Refrigeration. All rights reserved.			