

German Technology, Since 1929.

www.focusun.com

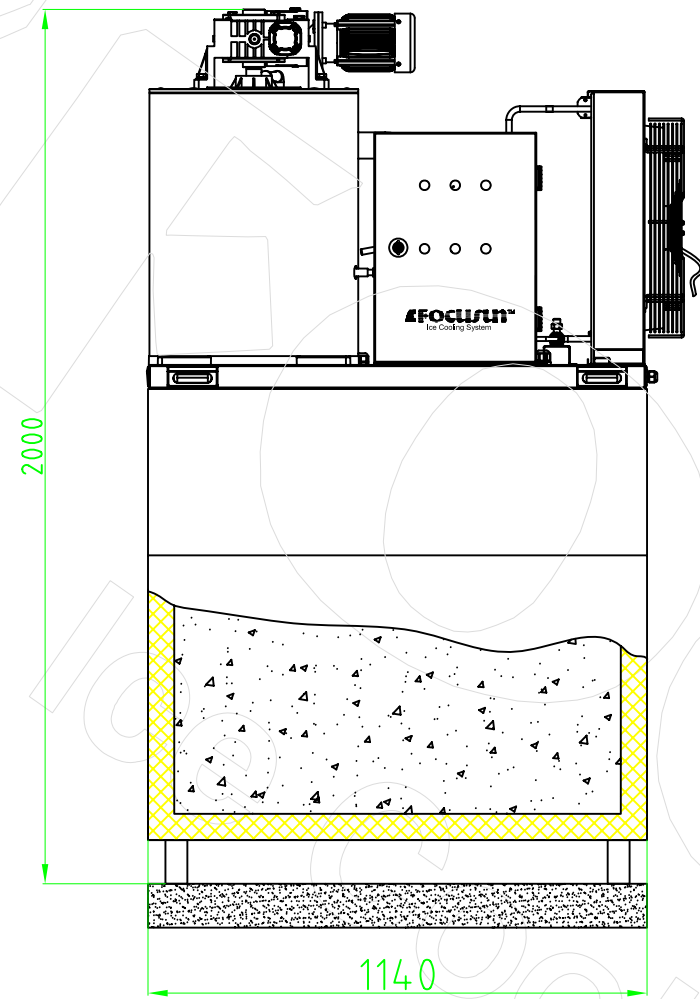

Flack Ice Machine:800kg

Ice Storage room:300kg

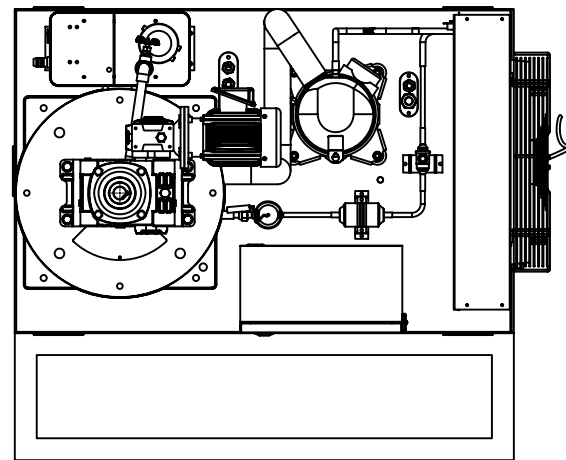
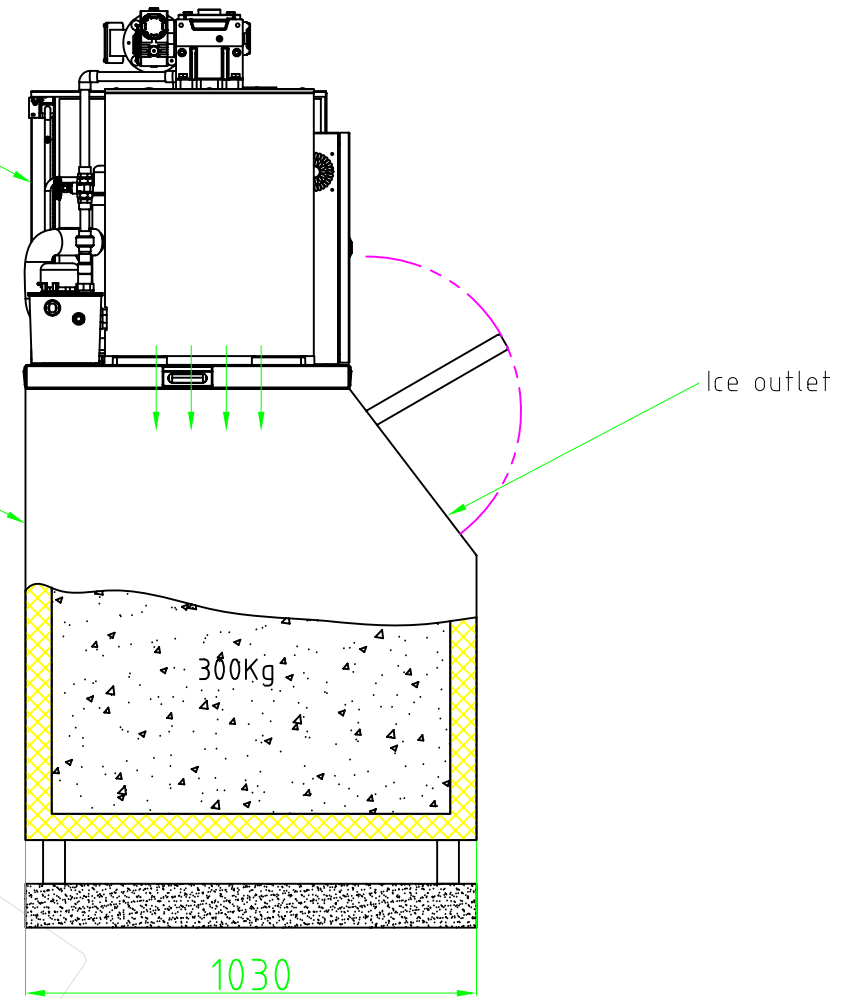

WORKING CONDITIONS

Air Temperature:	35°C
Water Temperature:	25°C
Power:	380V/3P/50Hz

SPECIFICATIONS

Condensing Temperature:	45°C
Evaporative Temperature:	-20°C
Refrigerant Capacity Need:	5.21kw
Compressor refrigerating Capacity:	5.63kw
Operating power:	3.9kw
Installation Power:	5.2kw
Condensor Capacity:	8.25kw
Daily Ice Capacity:	1MT
Ice Receiver Capacity:	300kg
Ice Degree:	-5°C, 1.5-2.0mm
Machine Size:	L1140×W1030×H2000mm
Equipment Weight:	0.36MT
Refrigerant:	R22

FOCUSUN™
Ice Cooling System

File Name:
Product No.:
Scale: Page: 01
Edition: 1st Version Pages: 01

Designer: _____ Date: _____
Checked By: _____ Date: _____
Approved By: _____ Date: _____

Product Name
FIF-8AH+FIS-300KG
© 2009-2013, Focusun Refrigeration. All rights reserved.